

Features

UL listed as an overload relay.

15 parameters can be programmed for maximum protection.

Digitally programmable for precise customization.

Last fault memory provides instant troubleshooting diagnostics.

Recordable voltage, current, last four faults, KWh usage, and power factor with communications package.

Compact design saves precious panel space.



PumpSaver
SUBMERSIBLE
PUMP PROTECTOR

77C-KW/HP
77C-LR-KW/HP

Overload Relay

Engineered
Protection

The Model 77C-KW/HP has important advantages over current monitors in many protection applications. Any motor load that has a small or very non-linear change in current vs. load requires the use of a power monitor for underload, dry run and dead-head protection. The change in power vs. load is more linear for most motor loads and is greater in magnitude than the change in current in all motor loads. This is because power measurements take into account both power factor (pf) and current.

Small motors, those under 3 hp and especially fractional horsepower, exhibit small changes in current vs. load, but the change in power is large. When larger motors are derated (run below their rated horsepower) the change in current is small vs. load, but again, the change in power is large and linear. Other typical applications include slower speed mixer or agitator motors up to 50 hp and beyond. These motors and others that run slower than around 3400 rpm usually have small current changes vs. load.

Magdrive and can pumps tend to be small horsepower, positive displacement-type pumps. These pumps need the high sensitivity of a power monitor to protect them from dry run using the underpower feature and dead-head conditions using the underpower feature if the motor decouples from the pump, and the overpower feature if the motor does not decouple.

The built-in UL Listed/CSA approved overload, current unbalance, reverse phase, single-phase and other protection features are significant benefits over similar products. The Modbus communications capability allows this device to be directly integrated with the SymCom RM-1000 and RM-2000 remote displays or other remote monitoring and control equipment.

Protects Single-Phase motors from:

- Overload
- Underload
- Jams
- Low voltage
- High voltage
- Rapid cycling

Additional Features:

- Fully programmable
- CSA approved
- CE compliant
- UL and cUL listed
- Automatic or manual reset
- Tamper guard
- RS485 communication port (with pn RS485MS-2W)
- Remote reset
- Surface and DIN rail mount
- Alphanumeric LED diagnostic display
- Last fault memory
- 5-year warranty
- Made in USA

Pumpsaver®

SUBMERSIBLE PUMP PROTECTOR

Specifications
•
Operating Points
•
Special Options

77C-KW/HP & 77C-LR-KW/HP Overload Relay

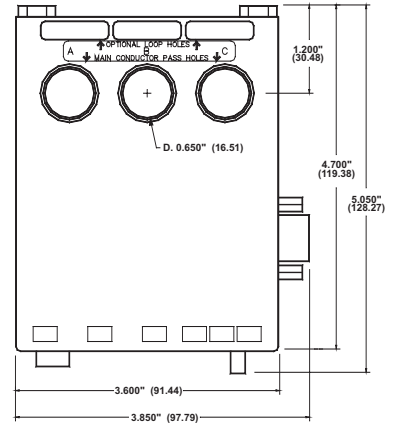
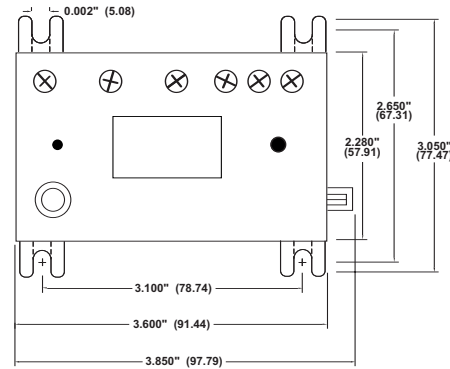

SPECIFICATIONS	OVERLOAD RELAY
Electrical	
Input Voltage	100-240 VAC, 1Ø
Frequency	50-60 Hz
Motor Full Load Amp Range - 77C-KW/HP	2-25 Amps, 3Ø(Loops Required) 26-90 Amps, 3Ø(Direct) 91-800 Amps, 3Ø(External CT's)
Motor Full Load Amp Range - 77C-LR-KW/HP	1.0 Amps - 2.5 Amps (1 Loop) 2.0 Amps - 9.0 Amps (Direct)
Short Circuit Withstand Rating	100kA per UL and CSA
Power Consumption	5W (Maximum)
Output Contact Rating SPDT (Form C)	Pilot duty rating: 480 VA @ 240 VAC General purpose: 10A @ 240 VAC
Expected Life	
Mechanical	1 x 10 ⁷ operations
Electrical	1 x 10 ⁷ operations at rated load
Accuracy at 25° C (77° F)	
Voltage	±1%
Current	±3% (Direct, No External CT's)
Timing	5% ± 1 second
Repeatability	
Voltage	± 0.5% of nominal voltage
Current	± 1% (Direct, No External CT's)
Safety Marks	
UL	UL508, UL1053
CE	IEC 60947-1, IEC 60947-5-1
Standards Passed	
Electrostatic Discharge (ESD)	IEC 1000-4-2, Level 3, 6kv contact, 8kv air
Radio Frequency Immunity (RFI), Conducted	IEC 1000-4-6, Level 3 10V/m
Radio Frequency Immunity (RFI), Radiated	IEC 1000-4-3, Level 3 10V/m
Fast Transient Burst	IEC 1000-4-4, Level 3, 3.5 kv input power
Surge	
IEC	1000-4-5 Level 3, 2kv line-to-line; Level 4, 4kv line-to-ground
ANSI/IEEE	C82.41 Surge and Ring Wave Compliance to a level of 6kv line-to-line Meets UL508 (2 x rated V +1000V for 1 minute)
Hi-potential Test	
Vibration	IEC 68-2-6, 10-55Hz, 1mm peak-to-peak, 2 hours, 3 axis
Shock	IEC 68-2-27, 30g, 3 axis, 11ms duration, half-sine pulse
Mechanical	
Dimensions	3.1\"/>
Terminal Torque	7 inch•lb
Enclosure Material	polycarbonate
Weight	1.2 lbs
Maximum Conductor Size Through 777	0.85\"/>
Environmental	
Temperature Range	Ambient Operating: -20° - 70° C (-40° - 158°F) Ambient Storage: -40° - 80° C (-40° - 176°F)
Pollution Degree	3
Class of Protection	IP20, NEMA 1
Relative Humidity	10-95%, non-condensing per IEC 68-2-3
Programmable Operating Points	
Range	
LV- Low Voltage Threshold	85V - HV Setting
HV- High Voltage Threshold	LV Setting - 264V
MULT- # of Conductors or CT Ratio (XXX:5)	77C: 1-10 Conductors or 100-800 Ratio 77C-LR: 1 or 2 (20-100A) + MULT or 80-120% of CT Primary
OC- Overcurrent Threshold	2 - 25% or 999
CUB- Current Unbalance Threshold	5, J5, 10, J10, 15, J15, 20, J20, 30, J30, or Lin (linear)
TC- Overcurrent Trip Class *	0, 2 - 500 Minutes/Seconds
RD1- Rapid Cycle Timer	2 - 500 Minutes/Seconds
RD2- Restart Delay After All Faults Except Undercurrent (motor cool down timer)**	2 - 500 Minutes/Seconds
RD3- Restart Delay After Undercurrent (dry well recovery timer)	2 - 500 Minutes/Seconds
#RU- Number of Restarts After Undercurrent	0, 1, 2, 3, 4, A(Automatic)
ADDR- RS485 Address	A01- A99
#RO-Number of Restarts After Overcurrent	0, 1, 2, 3, 4, A(Automatic)
LP/PWS (PWS = LP Range)	1 = 0.01 - 0.99 KW 5 = 0.01 - 0.99 HP 2 = 1.00 - 9.95 KW 6 = 1.00 - 9.95 HP 3 = 10.0 - 99.5 KW 8 = 10.0 - 99.5 HP 4 = 100 - 650 KW 9 = 100 - 650 HP

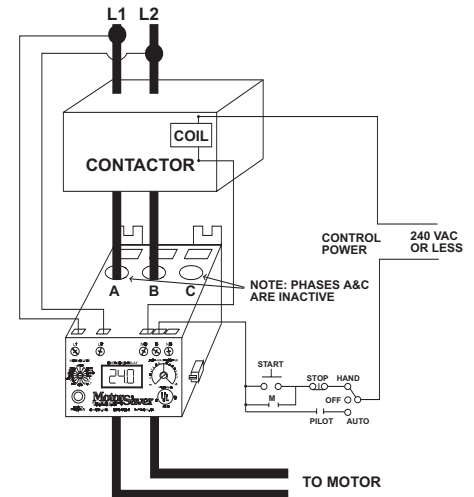
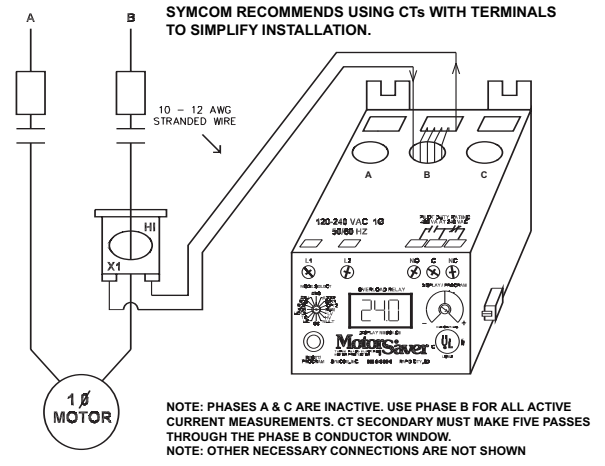

* If J Prefix is displayed in trip class setting, jam protection is enabled. If programmed to Lin position, overcurrent trip delays are fixed linear-type delays set in OPT1 position.
** RD2 & RD3 can be changed from minutes to seconds under program position OPT2.

SETTING	RD2	RD3
0	Minutes	Minutes
1	Minutes	Seconds
2	Minutes	Minutes
3	Seconds	Seconds

SymCom warrants its microprocessor-based products against defects in material or workmanship for a period of five (5) years from the date of manufacture. All other products manufactured by SymCom shall be warranted against defects in material and workmanship for a period of two (2) years from the date of manufacture. For complete information on warranty, liability, terms, returns, and cancellations, please refer to the SymCom Terms and Conditions of Sale document.